





Camshafts

Special Tool(s)

 <p>ST1776-A</p>	<p>Adapter for 303-564 303-578 (T97T-6256-A)</p>
 <p>ST1777-A</p>	<p>Holding Tool, Camshaft Sprocket 303-564 (T97T-6256-B)</p>
 <p>ST1781-A</p>	<p>Socket, Camshaft Sprocket Nut 303-565 (T97T-6256-G)</p>
 <p>ST1775-A</p>	<p>Timing Tool, Crankshaft TDC 303-573 (T97T-6303-A)</p>
 <p>ST1780-A</p>	<p>Torque Wrench Extension 303-575 (T97T-6256-F)</p>

Material

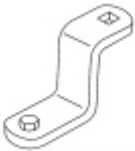
Item	Specification
<p>Motorcraft® SAE 5W-30 Premium Synthetic Blend Motor Oil XO-5W30-QSP (US); Motorcraft® SAE 5W-30 Super Premium Motor Oil CXO-5W30-LSP12 (Canada); or equivalent</p>	<p>WSS-M2C929-A</p>

Removal

Both sides

1. Remove the camshaft roller followers. For additional information, refer to [Camshaft Roller Follower](#) in this section.
2. **NOTE:** The RH and LH camshaft timing procedure must be carried out when either camshaft is serviced.

Rotate the crankshaft clockwise to position the No. 1 cylinder at Top Dead Center (TDC).

3. **NOTICE:** Do not rotate the engine counterclockwise. Rotating the engine counterclockwise will result in damage to the damper crank sensor speed wheel and incorrect timing of the engine.

NOTE: The Crankshaft TDC Timing Tool must be installed on the damper and should contact the engine block. This positions the piston at TDC.

Install the Crankshaft TDC Timing Tool.

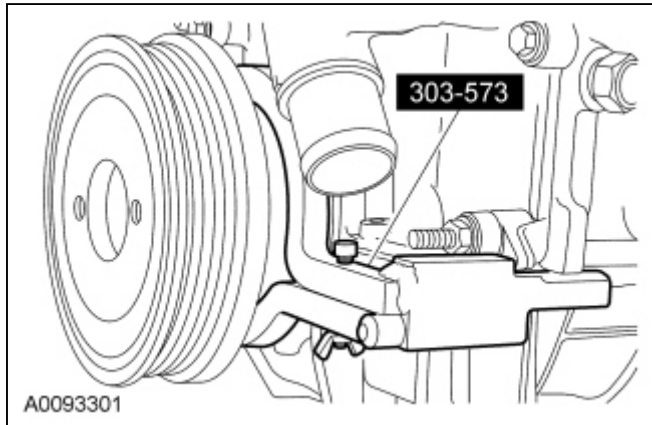

RH side

4. Install the Camshaft Sprocket Holding Tool and Adapter on the rear of the RH cylinder head and tighten the top 2 clamp bolts to 10 Nm (89 lb-in).

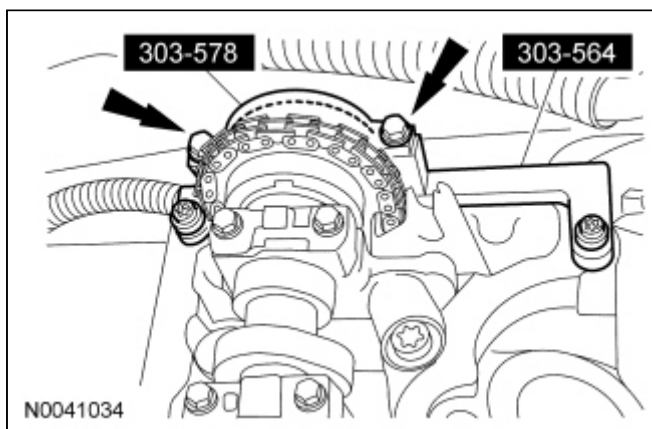

5. **NOTE:** The RH camshaft sprocket is a LH-threaded bolt.

Using the Torque Wrench Extension and the Camshaft Sprocket Nut Socket 303-565, loosen the camshaft sprocket bolt.

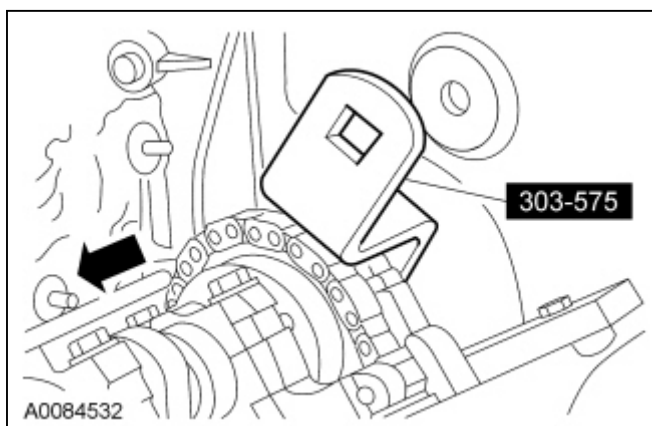

6. Remove the camshaft sprocket bolt and position the RH camshaft sprocket aside.

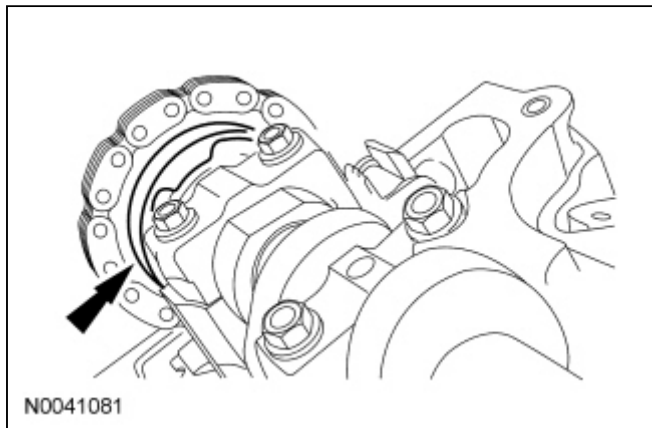

LH side

7. Install the Camshaft Sprocket Holding Tool and Adapter on the front of the LH camshaft and tighten the 2 top clamp bolts to 10 Nm (89 lb-in).

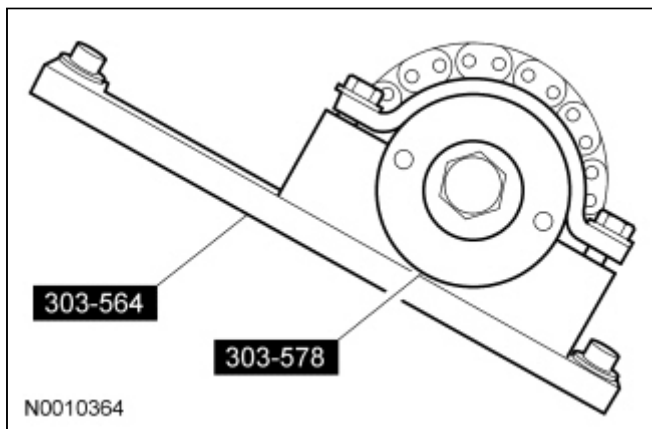

8. Loosen the bolt.

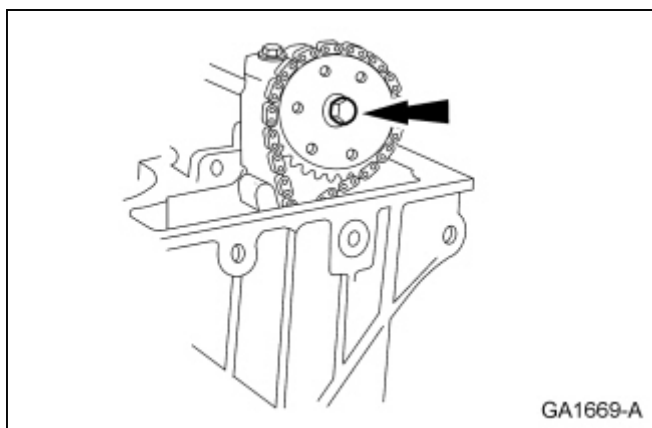

9. Remove the bolt and position the LH camshaft sprocket aside.

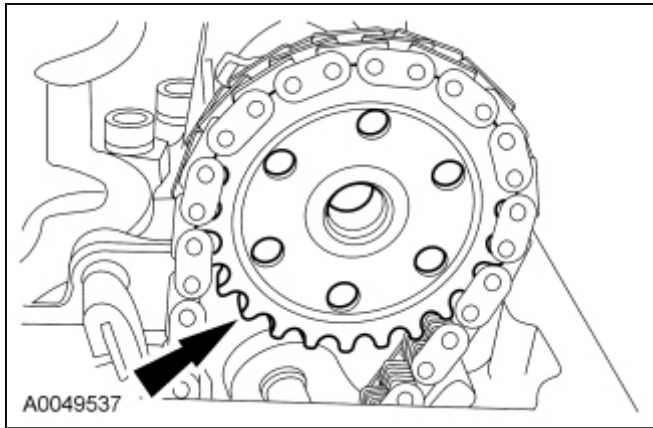

Both sides

10. **NOTE:** Mark the position of the camshaft bearing caps so they can be installed in their original positions.

Remove the bolts in the sequence shown and remove the camshaft bearing caps.

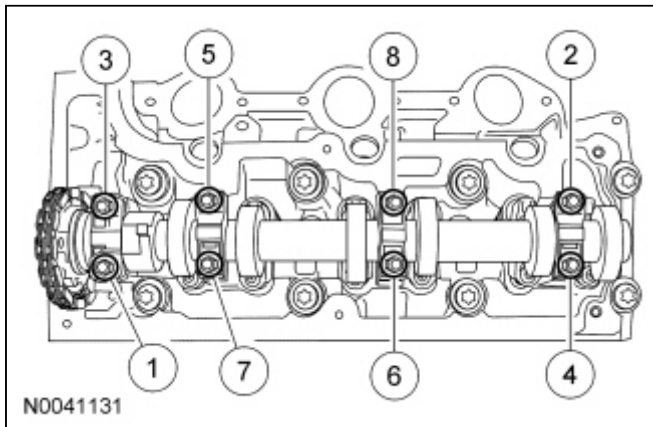

11. Remove the camshaft.

Installation

Both sides

1. **NOTE:** Lubricate the camshafts with clean engine oil.

Install the camshaft.

2. **NOTE:** Lubricate the camshaft bearing caps with clean engine oil.

NOTE: The camshaft bearing caps must be installed in their original positions.

NOTE: After installing the bolts, check the camshaft for free rotation.

Install the camshaft bearing caps and the bolts.

- Tighten the bolts in the sequence shown in 2 stages.
 - Stage 1: Tighten to 6 Nm (53 lb-in).
 - Stage 2: Tighten to 16 Nm (142 lb-in).

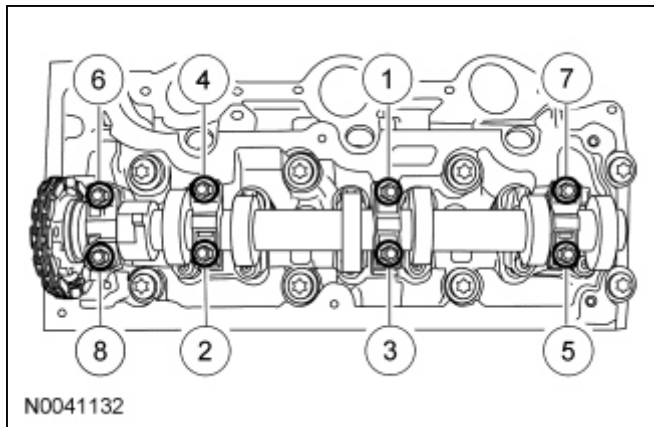

RH side

3. **NOTE:** The camshaft gear must turn freely on the camshaft. Do not tighten the bolt at this time.

Install the RH camshaft sprocket and loosely install the bolt.

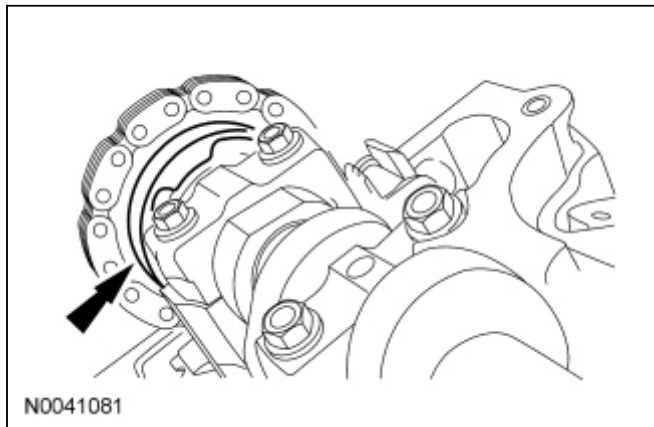

LH side

4. **NOTE:** The camshaft gear must turn freely on the camshaft. Do not tighten the bolt at this time.

Install the LH camshaft sprocket and loosely install the bolt.

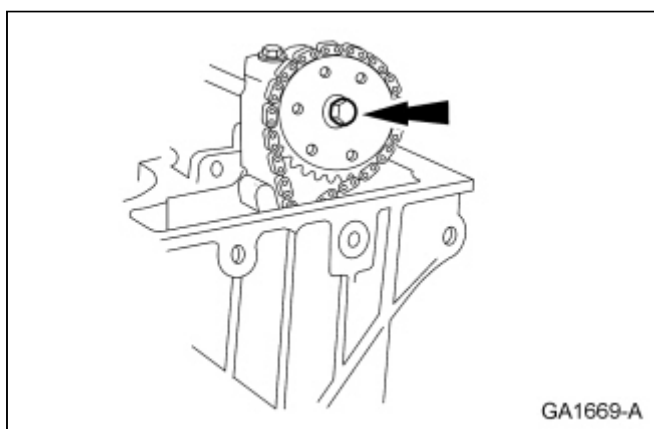

Both sides

5. Retime the camshafts. For additional information, refer to [Camshaft Timing](#) in this section.
6. Install the camshaft roller followers. For additional information, refer to [Camshaft Roller Follower](#) in this section.

